

Compact filter data

Model	Air Flow	Filtration area	Fan Model & Motor	Static Pressure	Compressed Air Consumption and Pressure (Clean , Dry and Oil free)	Filter Type See Picture	Dimension (mm)		
							A	B	H
B 610 F3	480 m³/h	6 m²	F3- 3Hp	160mm WG	4 m³/h 4.5 Bar	Type 1	625	700	1660
						Type 2	1660	700	625
B1210 F5	950 m³/h	12 m²	F5- 4Hp	260mm WG	7.5 m³/h 6.2 Bar	Type 1	1150	700	1660
						Type 2	1100	700	1150
B 1512 F5	1200 m³/h	15 m²	F5- 4Hp	250mm WG	7.5 m³/h 6.2 Bar	Type 2	1300	700	1150
						Type 3	1300	700	2600
B 2010 F8	1580 m³/h	20 m²	F8- 10Hp	330mm WG	7 m³/h 4.5 Bar	Type 2	1100	1100	1150
						Type 3	1100	1100	2450
B 3015 F8	2370 m³/h	30 m²	F8- 10Hp F11-12.5Hp	310mm WG 350mm WG	9 m³/h 4.5 Bar	Type 2	1600	1100	1150
						Type 3	1600	1100	2850
B 4515 F11	3560 m³/h	45 m²	F11-12.5Hp	320mm WG	12 m³/h 5.2 Bar	Type 2	1600	1100	1750
						Type 3	1600	1100	3600
B 6015 F11	4750 m³/h	60 m²	F11-12.5Hp F15- 20Hp	290mm WG 370mm WG	18 m³/h 6.2 Bar	Type 2	1600	1100	2200
						Type 3	1600	1100	4100

Type 1
Top removal without hopper

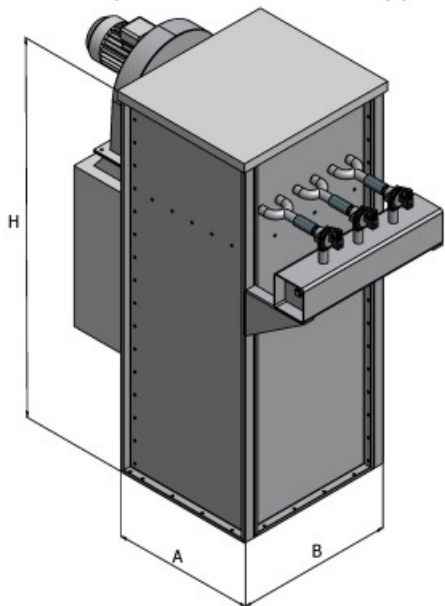

Type 2
Side removal without hopper

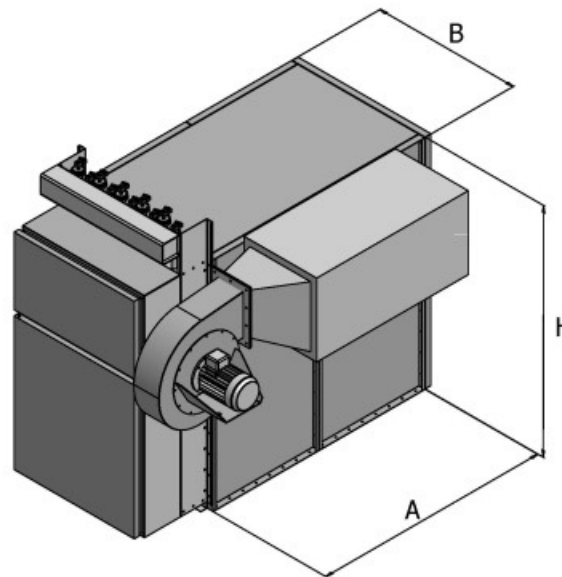

Type 3
Side removal with hopper

